

**STRAIGHT 2 HOLES FLANGE FLOATING JACK
SOLDER TYPE - CABLE .085 - PACK. 100**

R128.292.827
SERIES BMA COM

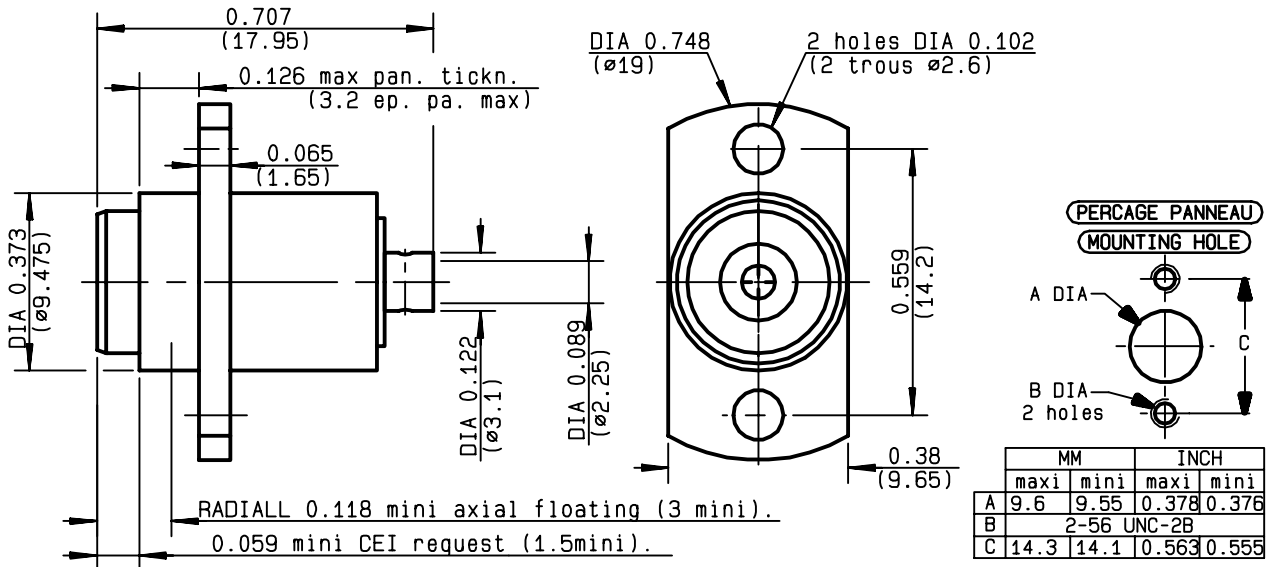

NOMINAL IMPEDANCE	50	Ω
FREQUENCY RANGE	0-22	GHz
TEMPERATURE RATING	-65/+125	$^{\circ}C$
V.S.W.R	1.07 +	.01 x F(GHz)Maxi
RF INSERTION LOSS	0.03	\sqrt{F} (GHz) dB Maxi
VOLTAGE RATING	350	Veff Maxi
DIELECTRIC WITHSTANDING VOLTAGE	1000	Veff Mini
INSULATION RESISTANCE	5000	M Ω Mini
HERMETIC SEAL	NA	Atm.cm ³ /s
LEAKAGE (pressurized only)	NA	
MECHANICAL DURABILITY	500	Cycles
WEIGHT	5.2	gr
SPECIFICATION		

CABLES : **KS 1**
RG 405

OTHERS CHARACTERISTICS

CABLE RETENTION	136	N Mini
CENTER CONTACT RETENTION		
Axial force - mating end	18	N Mini
Axial force - opposite end	18	N Mini
Torque	NA	cm.N Mini
RECOMMENDED TORQUES		
Mating	NA	cm.N
Panel nut	NA	cm.N
Clamp nut	NA	cm.N

CONNECTOR PARTS:	MATERIALS	FINISH	(all values are given in micrometers)
BODY	BRASS	BBR 2	
OUTER CONTACT	BRASS	BBR 2	
CENTER CONTACT	BRONZE	GOLD 1.3 OVER COPPER 2	
INSULATOR	PTFE	-	
GASKET	-	-	
OTHERS PIECES	BRASS	BBR 2	

ISSUE	CREATION DATE	FILE PART-NUMBER
9926A01	19/09/1996	EPC96-06



RADIALL[®]

BAFFERT

The information given here is subject to change without notice.
Design changes may be in order to improve the product .

Connect to the future



R128.292.827

ISSUE **9926A01** SERIES **BMA COM**

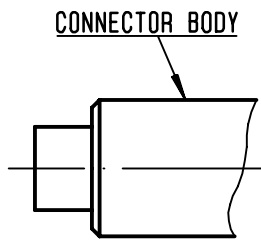

We recommend a thermal preconditioning cable .

①

Strip the cable .
 Stripping tool R282 051 000
 Positioner R282 062 000
 -
 -

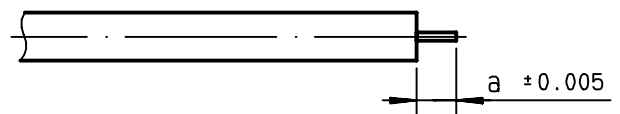

Stripping	a	b	c	d	e
inch	0.07	0	0	0	0
mm	1.78				

②

Trim cable center conductor .
 Trimmer R282 062 000
 -
 -

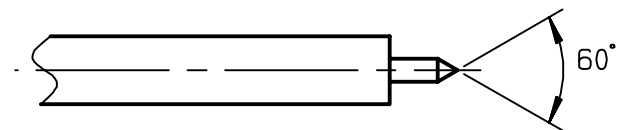

③

Slide cable into connector body until it contacts the body shoulder.
 Place sub assembly into the assembly jig R282 740 000 (or equivalent) with positioner R282 860 100 and tighten it .
 Solder body onto cable .
 Let the assembly cool down before removing it from the jig .
 Clean the solder area.

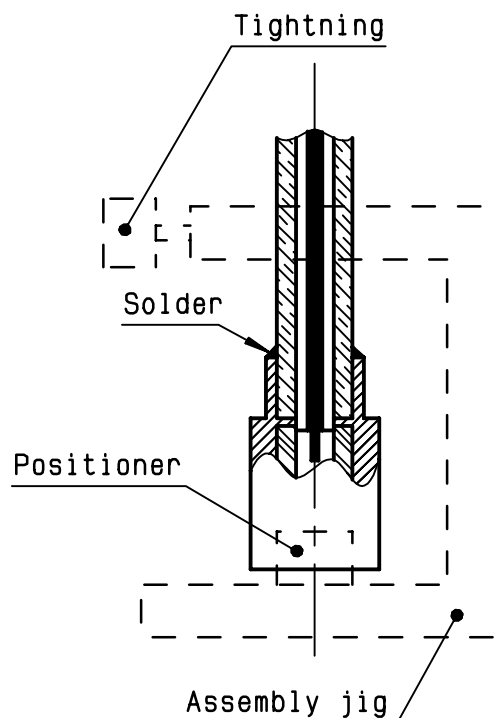



R128.292.827

ISSUE 9926A01 SERIES BMA COM

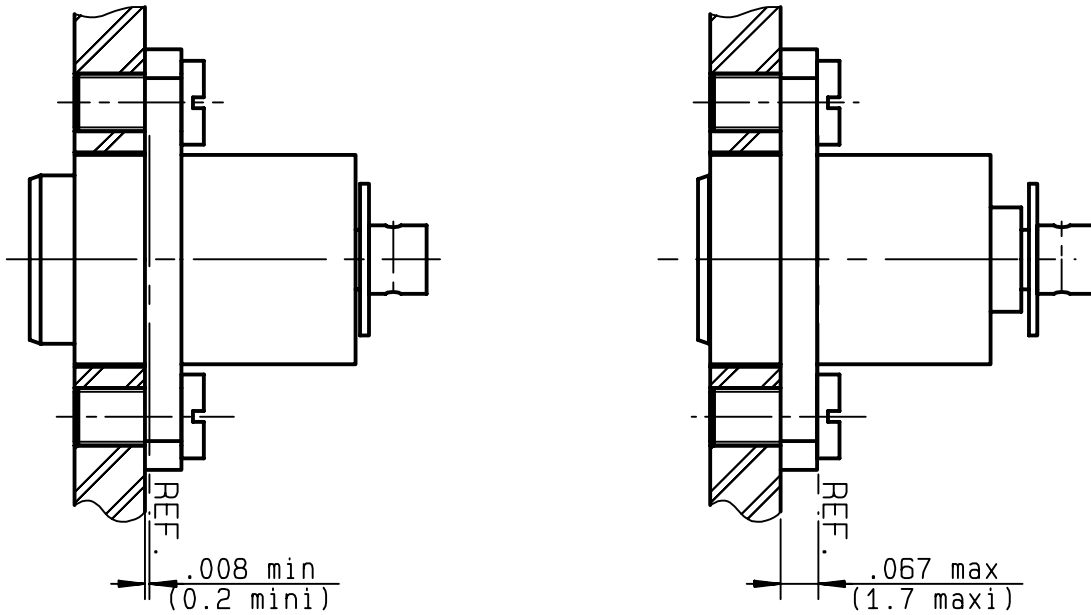

Allowed floats of this connector is as follows :

axial stroke : .06 inch

radial clearance : $\pm .0187$ inch

Greater hole pattern variation is allowed but at the sacrifice of the radial float .

